

GCSE Higher Tier Paper 2/3 preparation

How to use this booklet:

- Pick a topic (Choose one that you are not 100% confident on)
- Complete the questions
- Scan the QR code to view the worked solutions
- If you still don't feel confident go to one of the useful websites listed below and find some similar questions

Useful websites with exam practice and worked/video solutions:

<https://www.1stclassmaths.com/aqarevision>

<https://www.old.mathsgenie.co.uk/gcse.php>

<https://corbettmaths.com/2026/05/15/aqa-paper-2-and-3-june-2026/>



Contents of this booklet:

Topic	Page Number
Polygons	2
Transformation of functions	4
Similar Solids	6
Random Ratio Questions	8
Simultaneous equations	9
Vector Geometry	11
Algebraic Fractions	14
Averages	15
Bounds	17
Factorising	18
Form & solve equations	19
Functions	21
Histograms	23
Instantaneous rates of change	27
Iterative processes	30
Product rule for counting	32
Proportion questions	33
Pythagoras	36
Quadratic formula	38
Random number Questions	39
Repeated percentage change	41
Reverse percentages	43
Right angle triangle trigonometry	44
Sine & Cosine rules	46
Straight line graphs	49
Transformations	54
Volume of 3D shapes	57

Polygons

Q1.

Write down the sum of the **exterior** angles of any polygon.

Answer _____

(Total 1 mark)

Q2.

A regular pentagon is drawn inside a regular octagon as shown.

Not drawn accurately

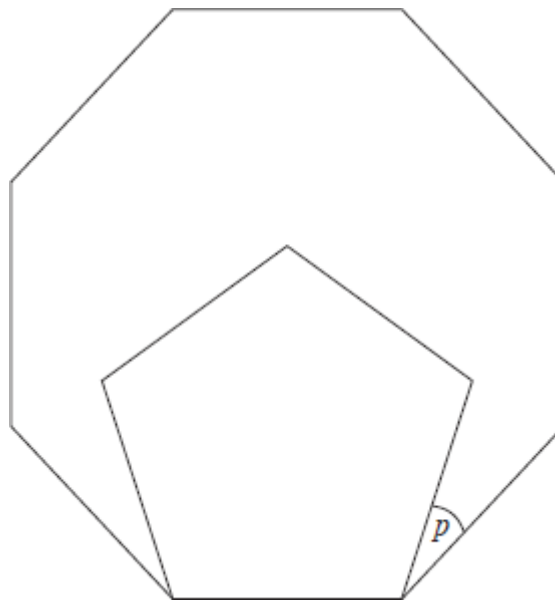

Calculate the size of angle p .
You **must** show your working.

Answer _____ degrees

(Total 3 marks)

Q3.

The diagram shows a rhombus inside a regular pentagon.

Not drawn accurately

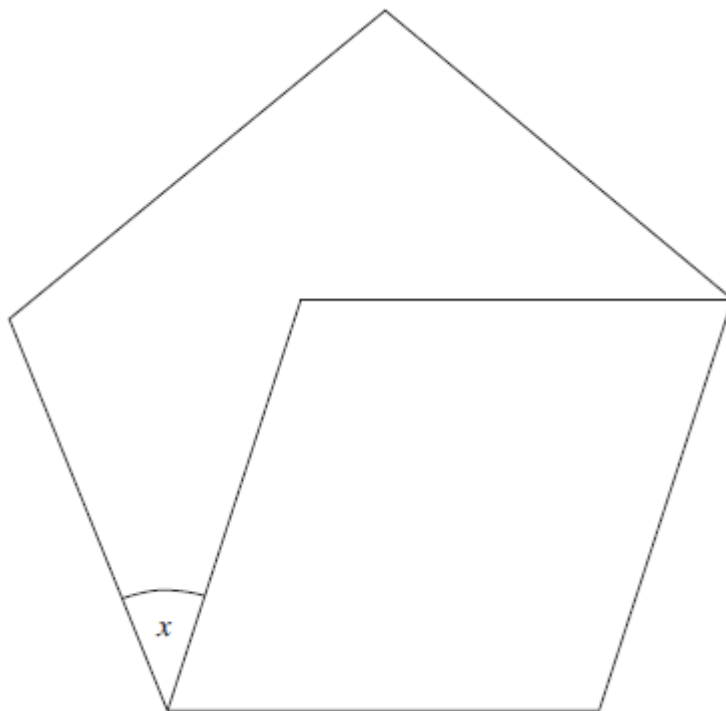

Work out the value of x .

Answer _____ degrees
(Total 4 marks)

Transformation of functions

Q1.

The grid shows the graph of $y = f(x)$

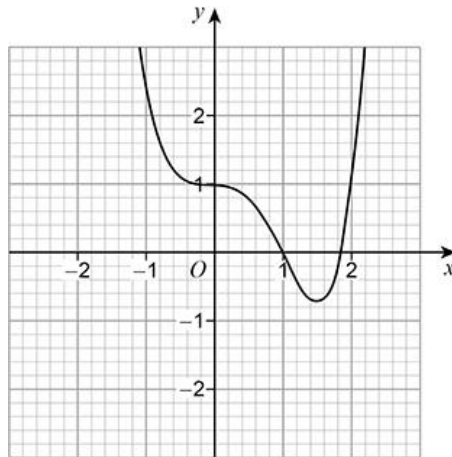

On the grid, draw the graph of $y = -f(x)$

(Total 2 marks)

Q2.

(7, 28) is a point on the graph $y = f(x)$

Circle the point which **must** be on the graph $y = f(x) + 2$

(7, 26)

(7, 30)

(5, 28)

(9, 28)

(Total 1 mark)

Q3.

Here are sketches of two graphs.

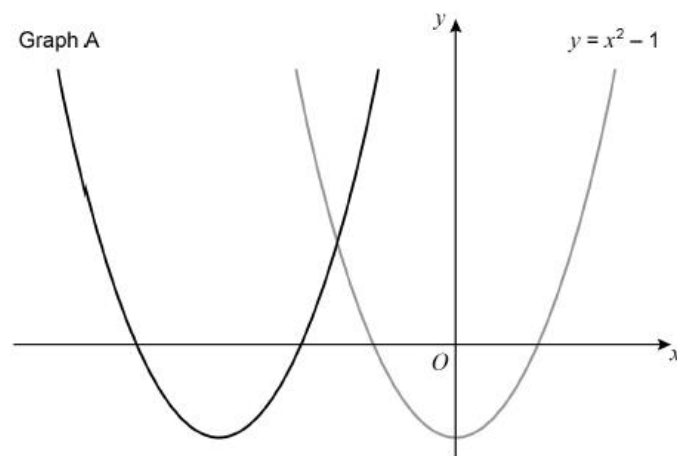

The graph of $y = x^2 - 1$ is translated 3 units to the left to give graph A.

(a) The equation of graph A can be written in the form $y = x^2 + bx + c$

Work out the values of b and c .

$b =$ _____

$c =$ _____

(3)

(b) The graph of $y = x^2 - 1$ is reflected in the x -axis to give graph B.

Work out the equation of graph B.

Answer _____

(1)

(Total 4 marks)

Similar solids

Q1.

Here are two similar cones.

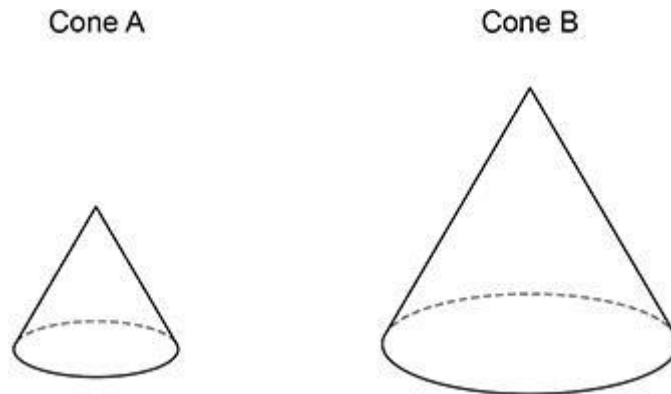

The surface area of cone A is 2 m^2

The surface area of cone B is 4.5 m^2

Work out the ratio radius of cone A : radius of cone B

Give your answer in the form $1 : n$

Answer _____ : _____

(Total 3 marks)

Q2.

A and B are similar solid cylinders.

base area of A : base area of B = $9 : 25$
--

Complete these ratios.

curved surface area of A : curved surface area of B = _____ : _____

height of A : height of B = _____ : _____

(Total 2 marks)

Q3.

Here are two similar solids, *A* and *B*.

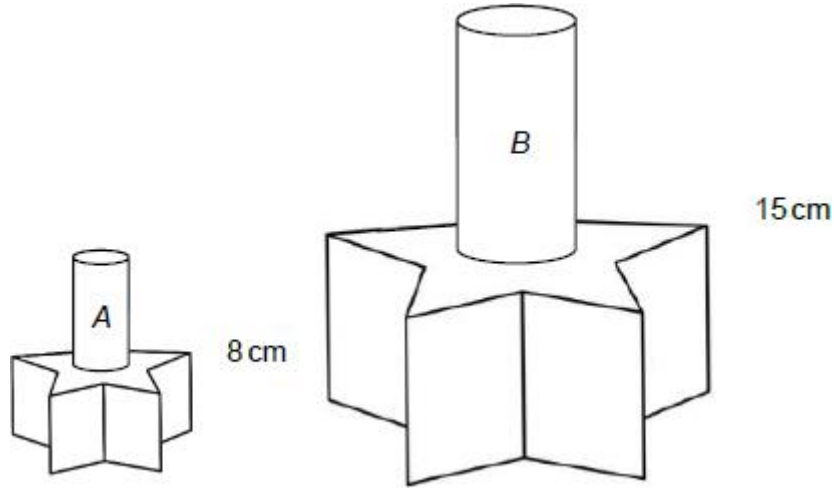

Solid *A* is 8 cm tall and solid *B* is 15 cm tall.

The volume of *A* is 250 cm^3

Is the volume of *A* approximately four times of the volume of *B*?

Yes

No

You **must** show your working.

(Total 4 marks)

Random ratio questions

Q1.

$$A : B = \frac{1}{5} : \frac{7}{10}$$

Write A as a fraction of B.

Answer _____

(Total 2 marks)

Q2.

Here is a cyclic quadrilateral.

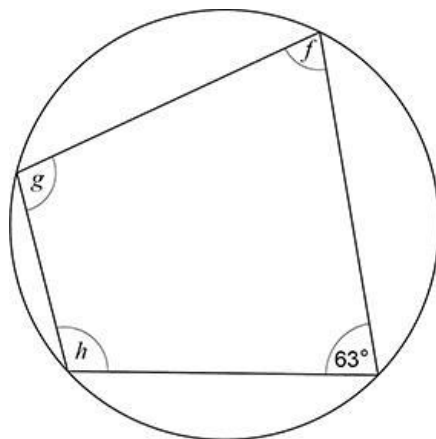

Not drawn accurately

$$f : g = 2 : 3$$

Work out $f : h$

Give your answer in its simplest form.

Answer _____ :

(Total 4 marks)

Q3.

Two objects, J and K, are applying pressure to areas of ground.

$$\text{pressure} = \frac{\text{force}}{\text{area}}$$

For J, the force is 18.9 newtons and the area is 0.45 m²

$$\text{pressure for J} : \text{pressure for K} = 7 : 8$$

$$\text{area for J} : \text{area for K} = 9 : 5$$

Work out the force for K.

Answer _____ newtons
(Total 4 marks)

Simultaneous equations

Q1.

Solve these simultaneous equations.

$$7x + 2y = 100$$

$$3x + 2y = 48$$

$x =$ _____ $y =$ _____
(Total 3 marks)

Q2.

The diagram shows a trapezium.

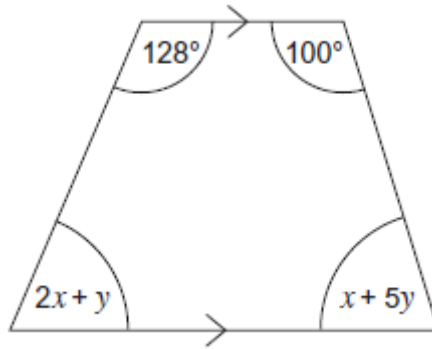

Work out the values of x and y .

(Total 5 marks)

Q3.

Use algebra to work out the x -coordinates of the points of intersection of

$$y = 3x^2$$

and $y = 4x + 2$

Give your answers to 1 decimal place.

Answer _____

(Total 5 marks)

Vector Geometry

Q1.

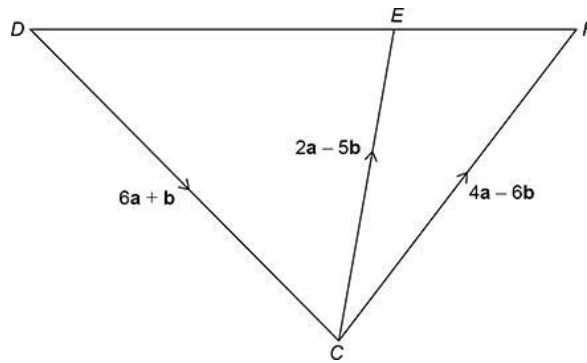

Not drawn accurately

Prove that DEF is a straight line.

(Total 4 marks)

Q2.

$ABCD$ is a quadrilateral.

AC and BD intersect at P .

$$\vec{AB} = 9\mathbf{b} - 2\mathbf{a}$$

$$\vec{BC} = 5\mathbf{a}$$

$$\vec{DC} = 10\mathbf{b}$$

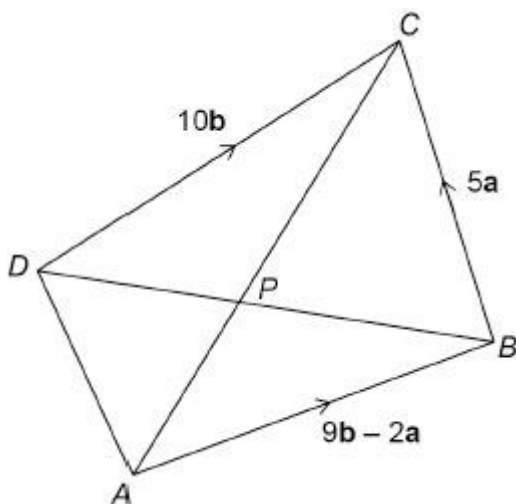

Not drawn accurately

$$BP : PD = 3 : 2$$

$$AP : PC = 1 : k$$

Work out the value of k .

You **must** show your working.

$$k = \underline{\hspace{2cm}}$$

(Total 5 marks)

Q3.

Not drawn accurately

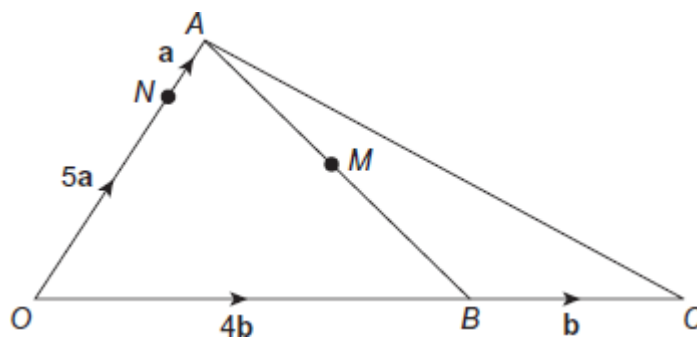

$$\vec{ON} = 5\mathbf{a}$$

$$\vec{NA} = \mathbf{a}$$

$$\vec{OB} = 4\mathbf{b}$$

$$\vec{BC} = \mathbf{b}$$

M is the midpoint of AB .

- (a) Show that $\vec{NM} = 2(\mathbf{b} - \mathbf{a})$

(2)

- (b) Work out the ratio $NM : NC$

Answer _____ : _____

(2)

(Total 4 marks)

Algebraic fractions

Q1.

Write $\frac{7}{2a^2} - \frac{3}{5a}$ as a single fraction in its simplest form.

Answer _____

(Total 2 marks)

Q2.

Simplify fully $\frac{8x^2 + 4}{5x} \times \frac{3x}{14x^2 + 7}$

You **must** show your working.

Answer _____

(Total 3 marks)

Q3.

Solve $\frac{x}{4} - \frac{2x}{x+2} = 1$

Give your solutions to 2 decimal places.

You **must** show your working.

Answer _____

(Total 6 marks)

Averages

Q1.

A school play takes place each day from Monday to Friday.

Here are the attendances on four of the days.

Monday	Tuesday	Wednesday	Thursday
72	83	88	97

For all **five** days, the mean attendance is 90

Work out the attendance on Friday.

Answer _____

(Total 3 marks)

Q2.

Rob records the time he takes to drive to work every day for 80 days.
The table shows information about the results.

Time, t (minutes)	Frequency
$20 \leq t < 25$	16
$25 \leq t < 30$	32
$30 \leq t < 40$	24
$40 \leq t < 60$	8
	Total = 80

Last year, the **mean** time Rob took to drive to work was 25 minutes.

Estimate the percentage increase in the **mean** driving time for these 80 days.

Answer _____ %
(Total 4 marks)

Q3.

Here is some information about the members of a basketball club.

	Number of members	Mean height of members
Junior	30	1.6 m
Senior	20	2.05 m

Work out the mean height of all 50 members of the club.
Give your answer as a decimal.

Answer _____ m
(Total 3 marks)

Bounds

Q1.

Jack is loading a van.

The van can safely carry 1375 kg of furniture.

Jack has already loaded 1200 kg of furniture to the nearest 50 kg

A table has mass 140 kg to the nearest 10 kg

Can the table safely be added to the furniture in the van?

You **must** show your working.

(Total 3 marks)

Q2.

Two sides of a triangle are measured to 1 decimal place.

The angle between the sides is measured to the nearest degree.

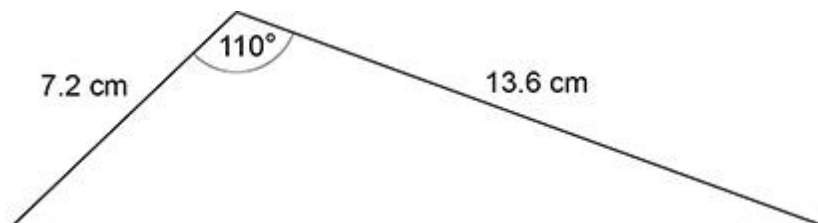

Not drawn accurately

Work out the upper bound for the area of the triangle.

You **must** show your working.

Answer _____ cm²

(Total 4 marks)

Q3.

A formula connecting speed (s), distance (d) and time (t) is

$$s = \frac{d}{t}$$

$d = 160$ to 2 significant figures

$t = 7.2$ to 2 significant figures

Work out the upper and lower bounds for s .

Give your answers to 3 significant figures.

Upper bound _____

Lower bound _____

(Total 4 marks)

Factorising

Q1.

Factorise fully $12t + 4t^3$

Answer _____

(Total 2 marks)

Q2.

Factorise fully $3x^2 + 23x + 30$

Answer _____

(Total 2 marks)

Q2.

AB is a straight line.

Both angles are given in degrees.

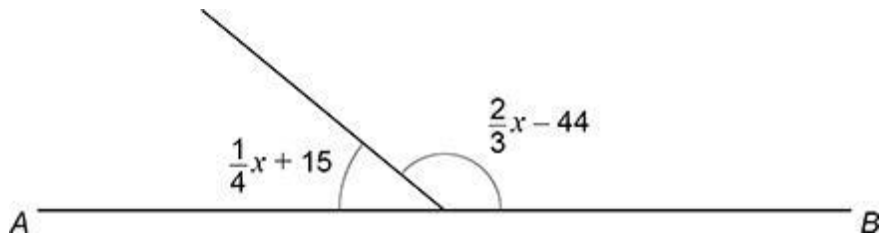

Not drawn accurately

By working out the value of x ,

work out the ratio smaller angle : larger angle

Answer _____ : _____

(Total 4 marks)

Q3.

Here is the plan of the floor of an L-shaped room.

All lengths are in metres.

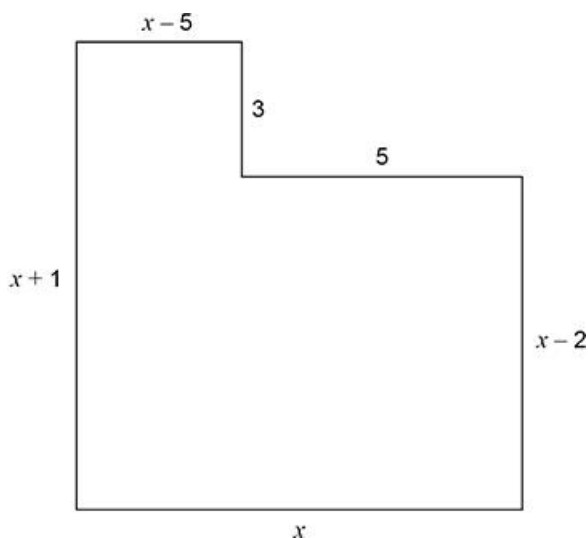

Not drawn accurately

(a) The area of the floor is 75 m^2

Show that $x^2 + x - 90 = 0$

(3)

(b) By factorising $x^2 + x - 90$ work out the value of x .

You **must** show your working

$x =$ _____

(2)

(Total 5 marks)

Functions

Q1.

$f(x) = 3^x$ and $g(x) = 3x + 7$

(a) Work out the value of $f(2) + g(5)$

Answer _____

(2)

(b) Work out the value of $gf(2)$

Answer _____

(1)

Answer _____

(Total 4 marks)

Histograms

Q1.

The police want to know how many cars exceed the speed limit.
An officer stands with a speed gun and records the speeds of 1000 consecutive cars.

- (a) Identify **one** possible source of bias for this experiment.

(1)

- (b) The grouped frequency table represents the speeds of the 1000 cars.

Speed, s (mph)	Frequency
$18 \leq s < 20$	80
$20 \leq s < 25$	440
$25 \leq s < 30$	360
$30 \leq s < 40$	120

On the grid below, show the data on a histogram.

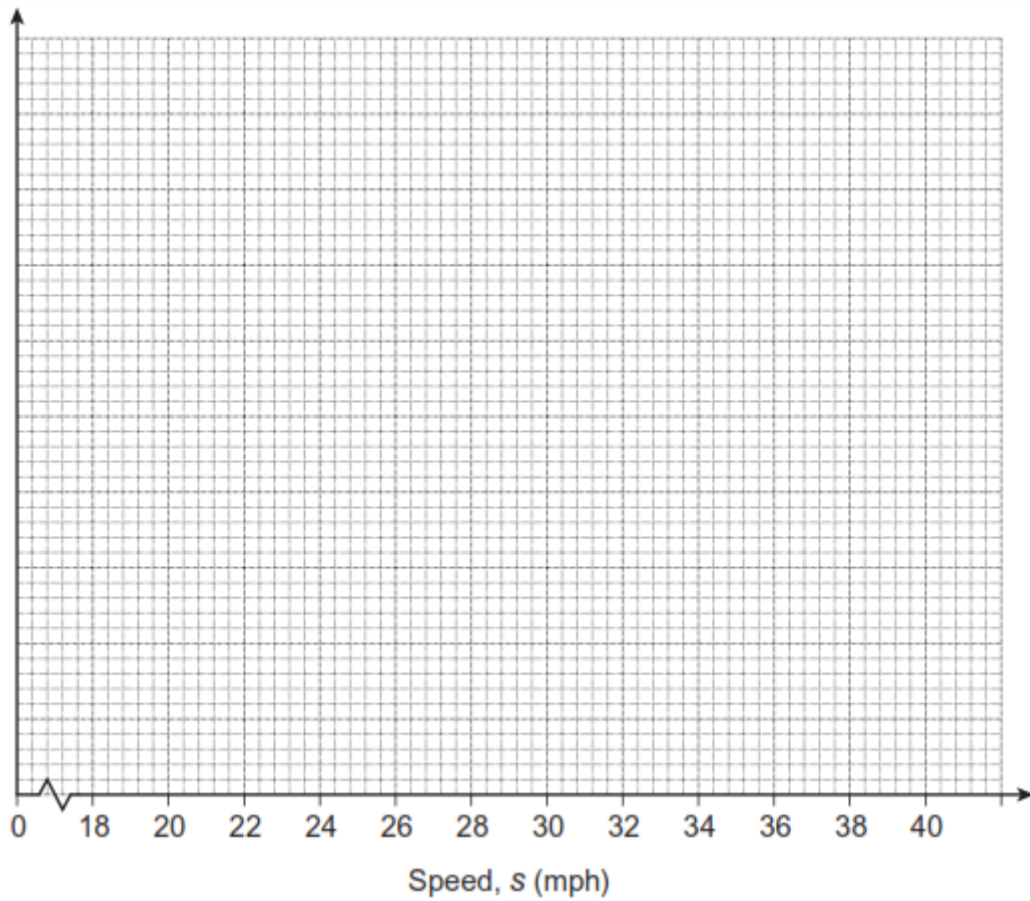

(4)

- (c) The speed limit for the road is 30 miles per hour.
Two cars are chosen at random from the 1000 cars.

Estimate the probability that **both** cars are at least 10% above the speed limit.

Answer _____

(3)

(Total 8 marks)

Q2.

The table and histogram give some information about the heights of 120 children.

Height, h (cm)	Frequency
$40 < h \leq 60$	30
$60 < h \leq 70$	20
$70 < h \leq 75$	
$75 < h \leq 95$	50
$95 < h \leq 105$	
	Total = 120

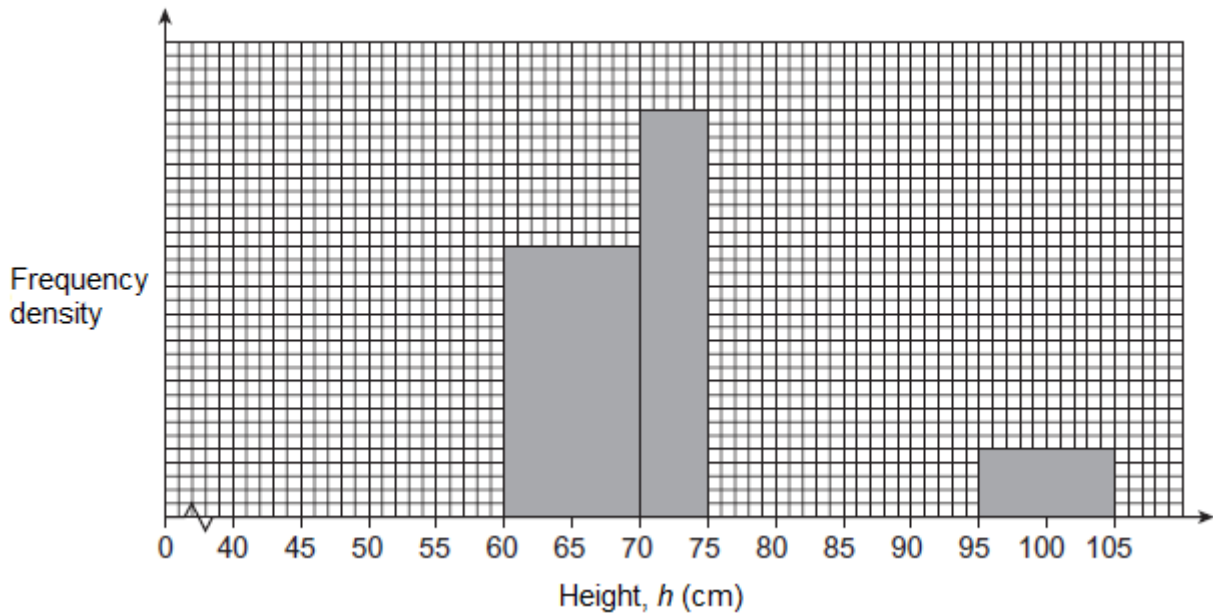

(a) Complete the table and the histogram.

(3)

(b) Calculate an estimate of the upper quartile of the heights of the 120 children.

Answer _____ cm

(2)

(Total 5 marks)

Q3.

The histogram shows information about the ages of 100 employees.

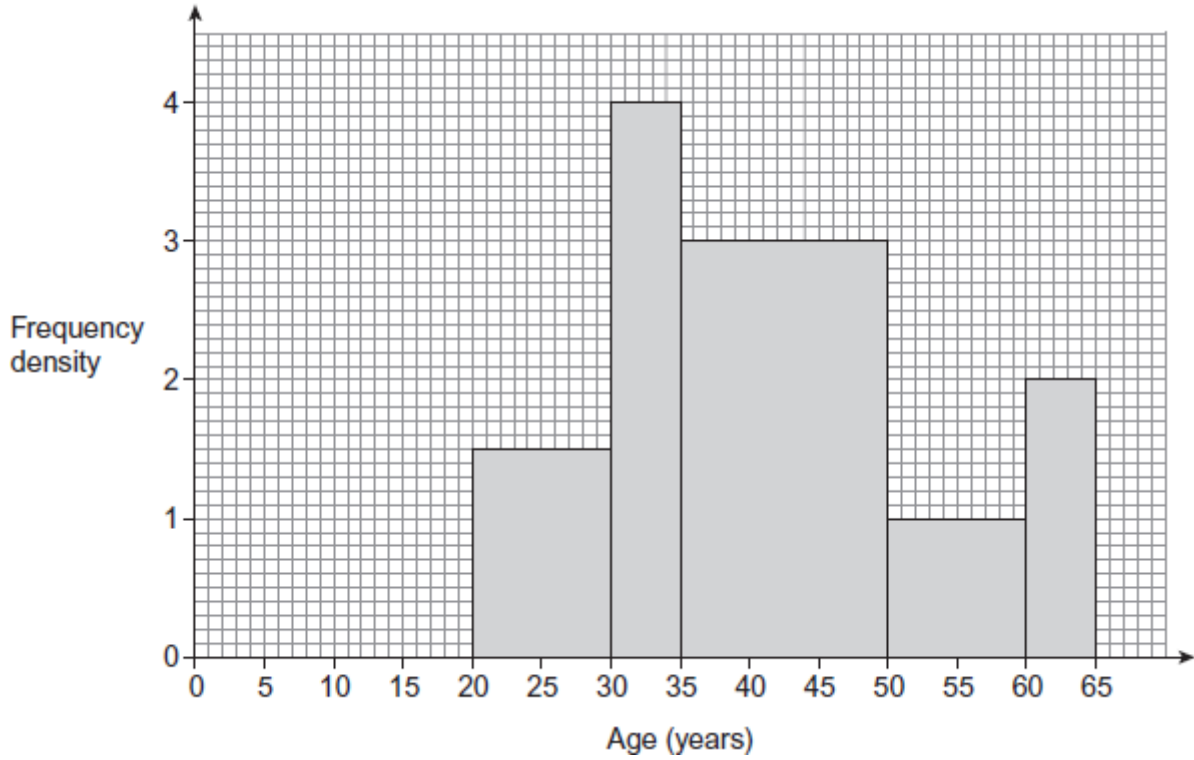

Work out an estimate of the median age of the employees.

Answer _____ years
(Total 4 marks)

Instantaneous rates of change

Q1.

Here is the velocity-time graph of a cyclist for 40 seconds.

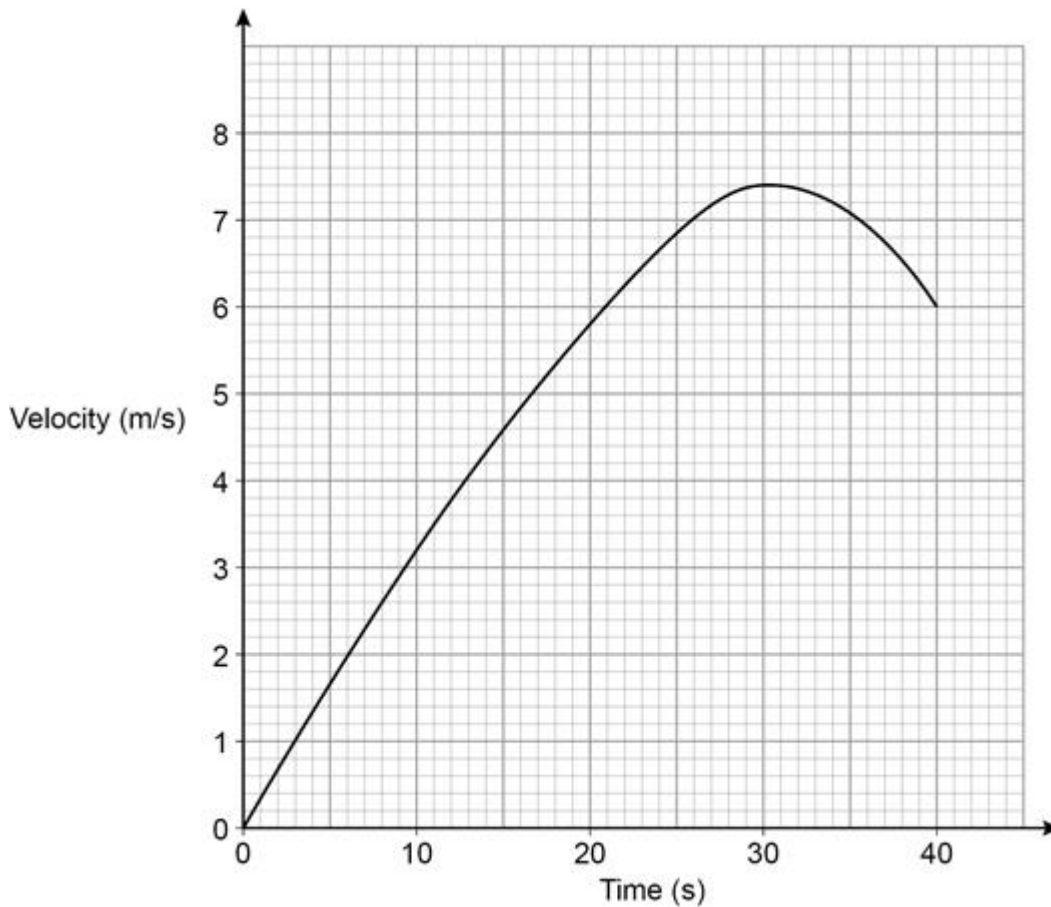

- (a) By dividing the area under the graph into four sections of equal widths, estimate the distance travelled during the 40 seconds.

Answer _____ m

(3)

- (b) Work out the average acceleration of the cyclist during the 40 seconds.
State the units of your answer.

Answer _____

(2)

(Total 5 marks)

Q2.

Leo runs for 12 seconds.

The graph shows his speed.

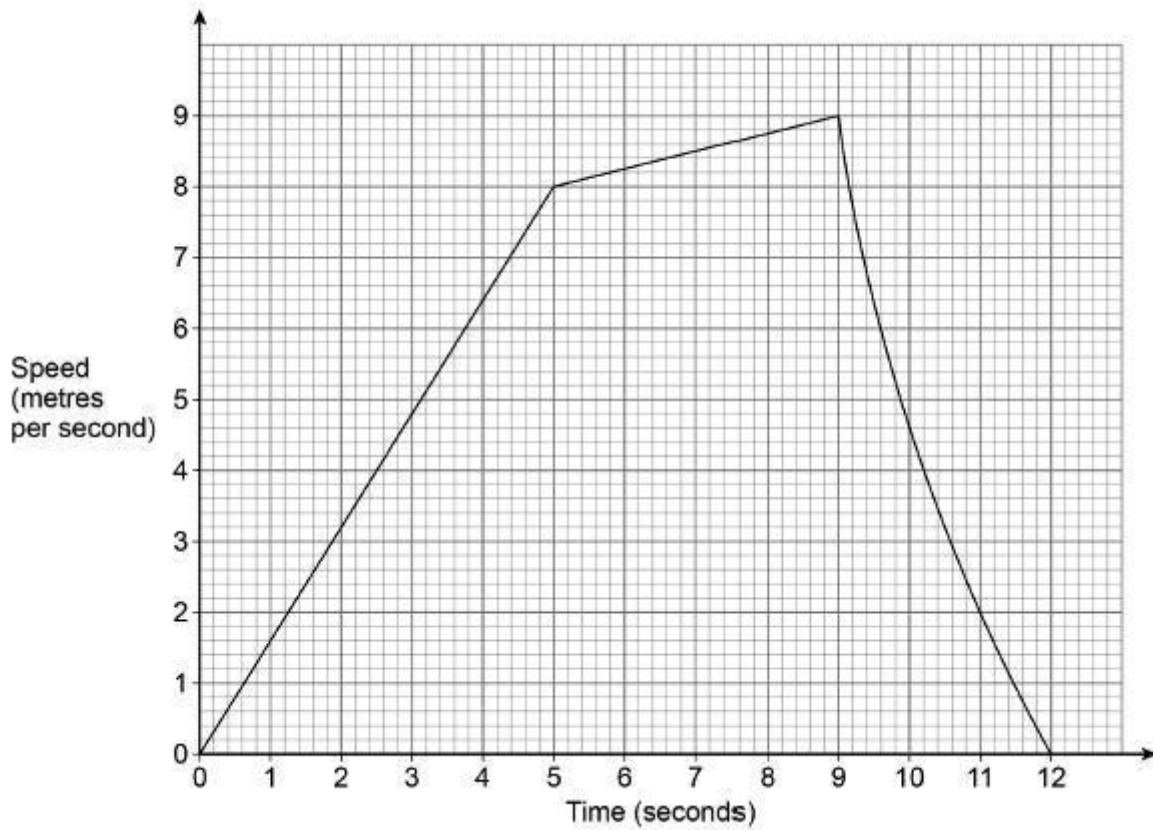

- (a) Show that the distance he runs is less than 67.5 metres.

(4)

- (b) Work out his average acceleration for the first 9 seconds.

State the units of your answer.

Answer _____

(2)

(Total 6 marks)

Q3.

The speed-time graph for a car's journey is shown.

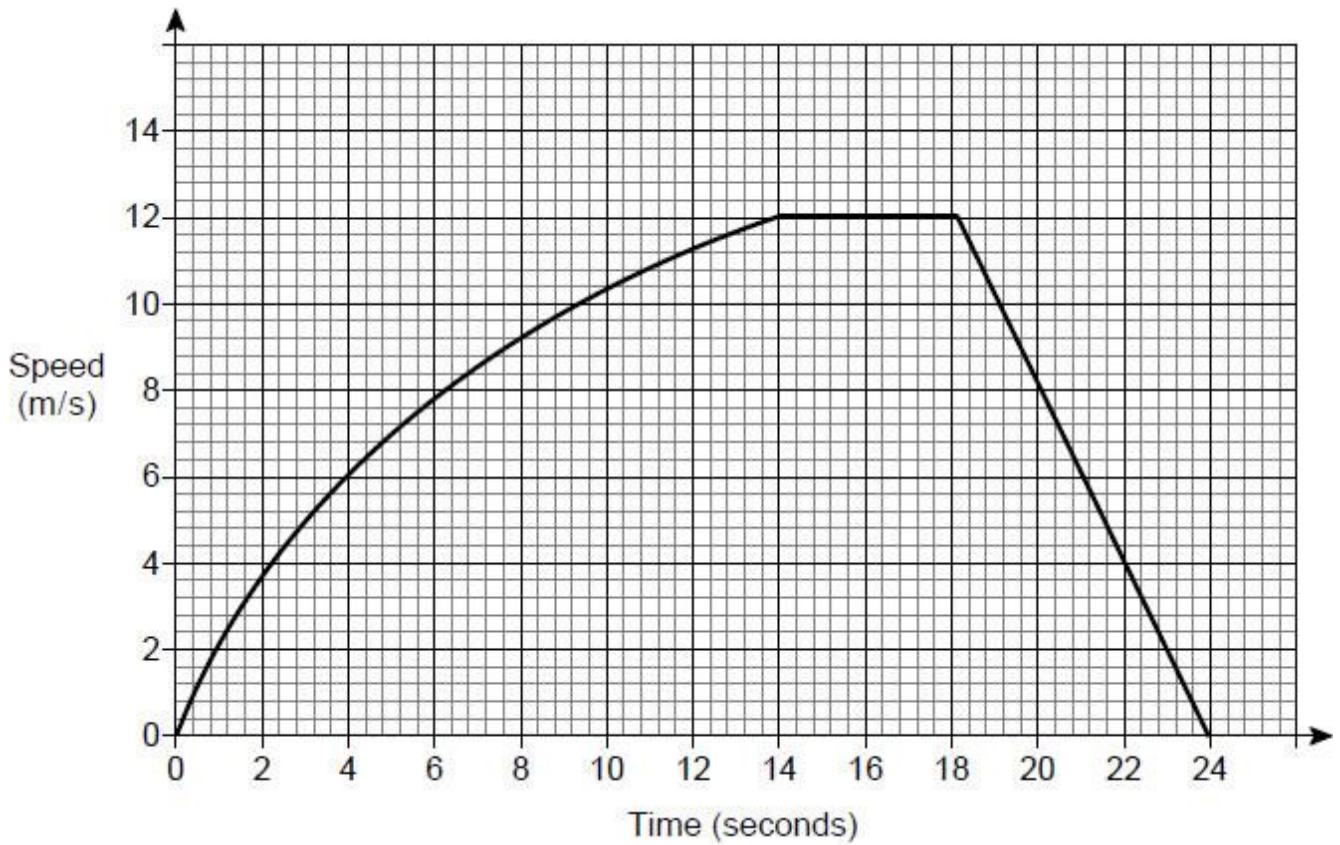

- (a) Estimate the acceleration at 6 seconds.
You **must** show your working.

Answer _____ m/s²

(3)

- (b) Estimate the average speed of the car for the journey.
You **must** show your working.

Answer _____ m/s

(4)

(c) Evaluate your answer to part (b).

Tick a box.

underestimate

exact

overestimate

Comment _____

(1)
(Total 8 marks)

Iterative processes

Q1.

Here is a formula for an iterative process.

$$u_{n+1} = \frac{24}{u_n} + 4$$

$$u_2 = 8$$

Work out the values of u_1 and u_3

$$u_1 = \underline{\hspace{2cm}} \quad u_3 = \underline{\hspace{2cm}}$$

(Total 3 marks)

Q2.

Rick borrows £1500 from a bank.

He pays back £100 each month.

This iterative formula works out the amount he still owes at the end of each month.

$$A_{n+1} = 1.02 \times A_n - 100$$

$$A_0 = 1500$$

Work out the amount he still owes at the end of the 2nd month.

Answer £ _____

(Total 3 marks)

Q3.

An approximate value of a root of an equation, x , can be found using the iterative formula

$$x_{n+1} = \sqrt[3]{5(x_n)^2 - 2x_n - 3}$$

The starting value is $x_1 = 4$

(a) Work out the values of x_2 and x_3

$$x_2 = \underline{\hspace{2cm}}$$

$$x_3 = \underline{\hspace{2cm}}$$

(2)

(b) By continuing the iteration, show that the value of x is more than 4.25

(1)

(Total 3 marks)

Product rule for counting

Q1.

Sofia makes 5-digit numbers using all of these cards.

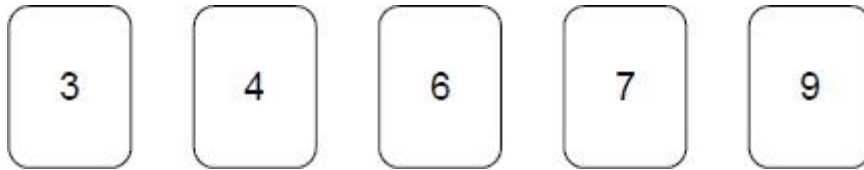

How many different **even** numbers can she make?

Answer _____

(Total 3 marks)

Q2.

Fatima is choosing a 4-digit code.

Each digit is a whole number from 0 to 9

She decides

all her digits will be odd numbers

no digits will be repeated.

How many different codes can she make?

Answer _____

(Total 2 marks)

Q3.

A vending machine has a different item in each section.

It sells

7 drinks, 3 of which are juice

5 snacks, 2 of which are fruit bars

11 meals, 4 of which are salad.

One drink, one snack and one meal are chosen at random.

Show that the probability of getting a juice, a fruit bar and a salad is **more** than 5%

(Total 3 marks)

Proportion questions

Q1.

H is inversely proportional to the cube root of L .

$H = 7$ when $L = 64$

(a) Work out an equation connecting H and L .

Answer _____

(3)

Pythagoras

Q1.

Use Pythagoras' theorem to work out the value of x .

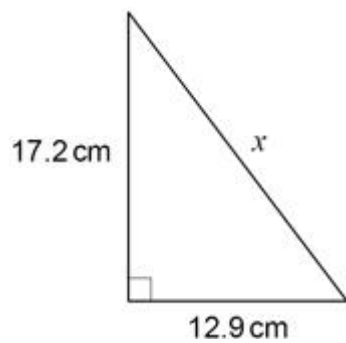

Not drawn accurately

$x =$ _____ cm
(Total 3 marks)

Q2.

A runner starts at A.
She follows this route.

$$A \rightarrow B \rightarrow C \rightarrow D \rightarrow A$$

Three of the distances are shown on the diagram.

Not drawn accurately

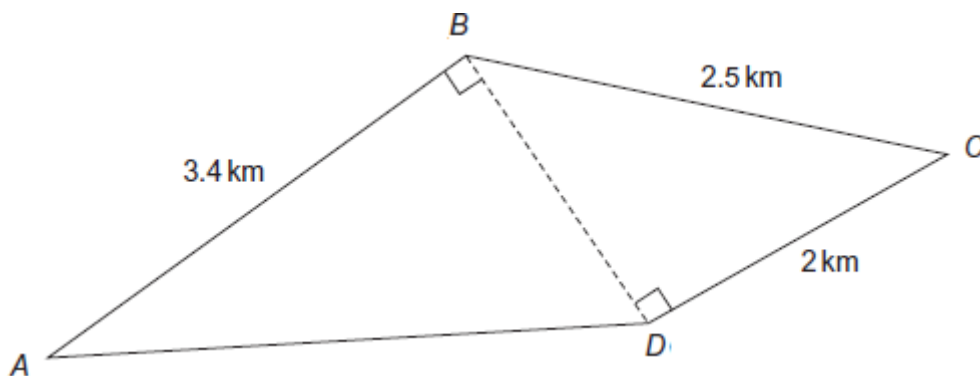

Work out the distance, in kilometres, from D to A.

Answer _____ km
(Total 5 marks)

Q3.

The diagram shows a right-angled triangle.

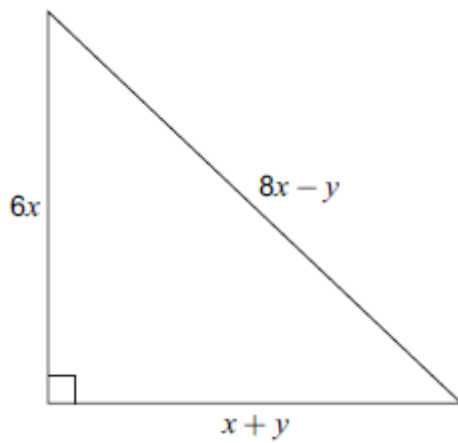

Not drawn accurately

Prove algebraically that $x : y = 2 : 3$

(Total 6 marks)

Quadratic formula

Q1.

Solve $3x^2 + 5x - 9 = 0$

Give your solutions as decimals.

Answer _____ and _____

(Total 2 marks)

Q2.

$$(x-9) = \frac{2(6-x^2)}{x+3} \quad \text{and} \quad x = \frac{d \pm \sqrt{e}}{f}$$

Work out one set of possible values for d , e and f

$$d = \underline{\hspace{2cm}}$$

$$e = \underline{\hspace{2cm}}$$

$$f = \underline{\hspace{2cm}}$$

(Total 4 marks)

Q3.

Solve $4x^2 + 7x - 3 = 0$

Give your answers to 2 decimal places.

$x =$ _____
(Total 3 marks)

Random number questions

Q1.

Write a number in each box to make the calculations correct.

$$\boxed{10} \div \boxed{-2} \times \boxed{} = \boxed{5}$$

$$\boxed{\frac{1}{3}} \times \boxed{} \times \boxed{6} = \boxed{8\pi}$$

(Total 2 marks)

Q2.

a and b are different prime numbers.

$$a^3 \times b^2 = 200$$

Work out the value of $a^4 \times b$

Answer _____
(Total 3 marks)

Q3.

The first two cube numbers are 1 and 8

Show that

the 3rd cube number can be written as the sum of three different prime numbers.

$$\square = \square + \square + \square$$

(Total 3 marks)

Q4.

k is a whole number between 40 and 50

The cube root of k is 3, to the nearest whole number.

Work out the **largest** possible value of k .

Answer _____

(Total 2 marks)

Q5.

Work out $\frac{4^6 - 11}{\sqrt{625} - 225}$

Circle your answer.

-61.6

-20.425

204.25

3870.56

(Total 1 mark)

Q6.

Circle the reciprocal of 8^5

8^{-5}

5^{-8}

-8^5

5^8

(Total 1 mark)

Q7.

Circle the largest number.

$0.\dot{5}$

0.55

0.545

$0.5\dot{4}\dot{5}$

(Total 1 mark)

Q8.

$a^b = 3$ where a is an integer and b is a proper fraction.

Work out **one** possible pair of values of a and b .

$a =$ _____ $b =$ _____

(Total 1 mark)

Q9.

Work out

cube root of 512 : reciprocal of 0.4

Give your answer in the form $n : 1$

Answer _____ : _____

(Total 3 marks)

Repeated percentage change

Q1.

£1800 is invested at 4% compound interest per year.

How many years will it take for the investment to be worth £2000?

Answer _____ years

(Total 4 marks)

Reverse percentages

Q1.

Greg and Hanna want to know if students at their school think lunchtime clubs are important.

Here are Hanna's results.

- 62% answered Important.
- 24% answered Not Important.
- The rest answered Don't Know.

93 students answered Important.

How many students answered Don't Know?

Answer _____

(Total 3 marks)

Q2.

I increase a number by 24%
The answer is 6014.

What number did I start with?

Answer _____

(Total 3 marks)

Q3.

It is estimated that there are 7 500 000 000 000 000 grains of sand on the world's beaches.

(Source University of Hawaii)

(a) Write this number in standard form.

Answer _____

(1)

(b) This number is 10% higher than the previous estimate.

Calculate the previous estimate.

Give your answer in standard form to two significant figures.

Answer _____

(3)

(Total 4 marks)

Right angle triangle trigonometry

Q1.

Use trigonometry to work out the size of angle x .

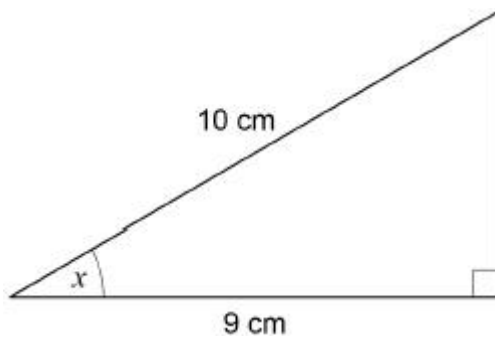

Not drawn accurately

Answer _____ degrees

(Total 2 marks)

Q2.

Use trigonometry to work out the length x .

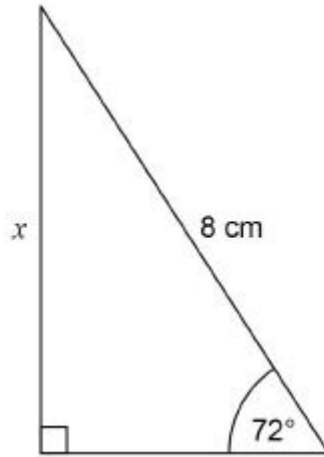

Not drawn accurately

Answer _____ cm
(Total 2 marks)

Q3.

$ABCDEFGH$ is a cuboid.

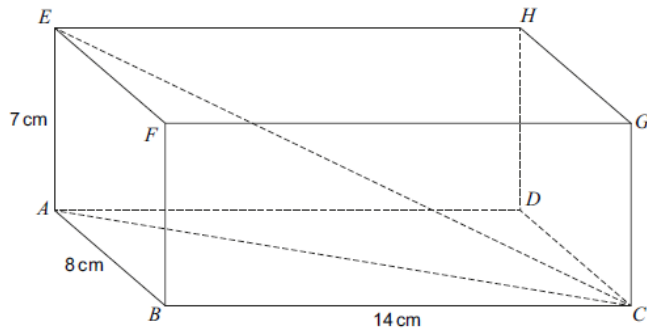

Work out the angle between EC and $ABCD$.

Answer _____ degrees
(Total 3 marks)

Sine & Cosine rules

Q1.

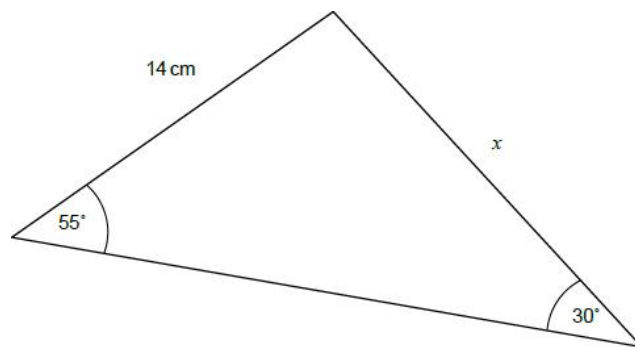

Not drawn accurately

Work out the value of x

Answer _____ cm
(Total 2 marks)

Q2.

A shape is made by joining triangle ABC to a semicircle with diameter AC .

Not drawn accurately

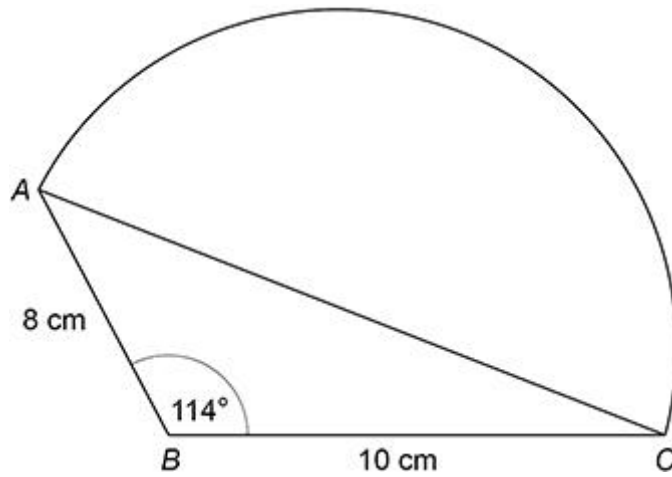

Work out the **total** area of the shape.

Answer _____ cm^2
(Total 5 marks)

Straight line graphs

Q1.

Draw the graph of $y = 1 - \frac{1}{2}x$ for values of x from -2 to 4

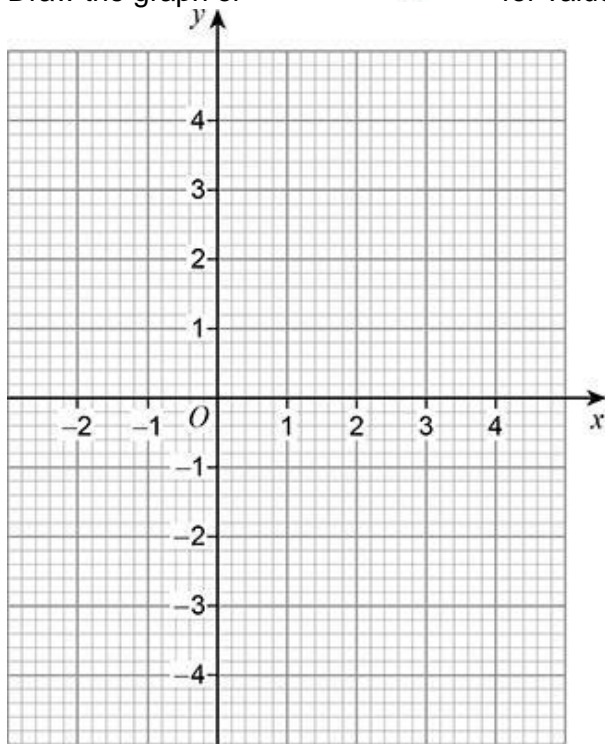

(Total 3 marks)

Q2.

Work out the equation of the line shown.

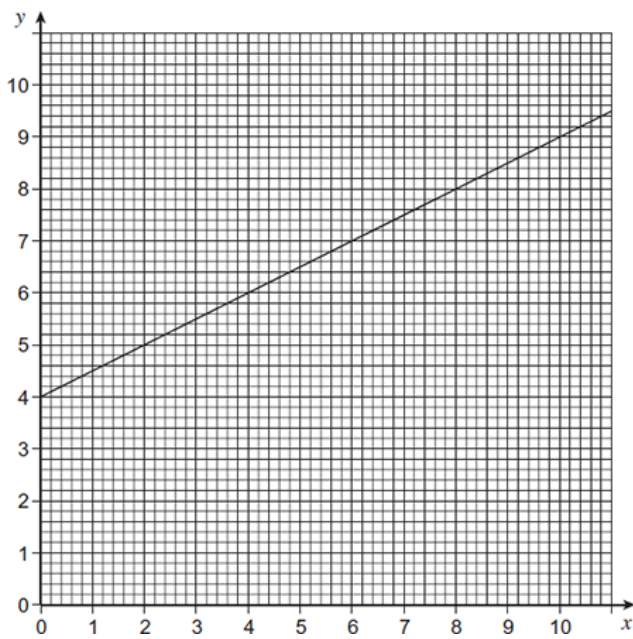

Answer _____

(Total 3 marks)

Q3.

A straight line passes through points $A(-5, 9)$, B and $C(3, -7)$.

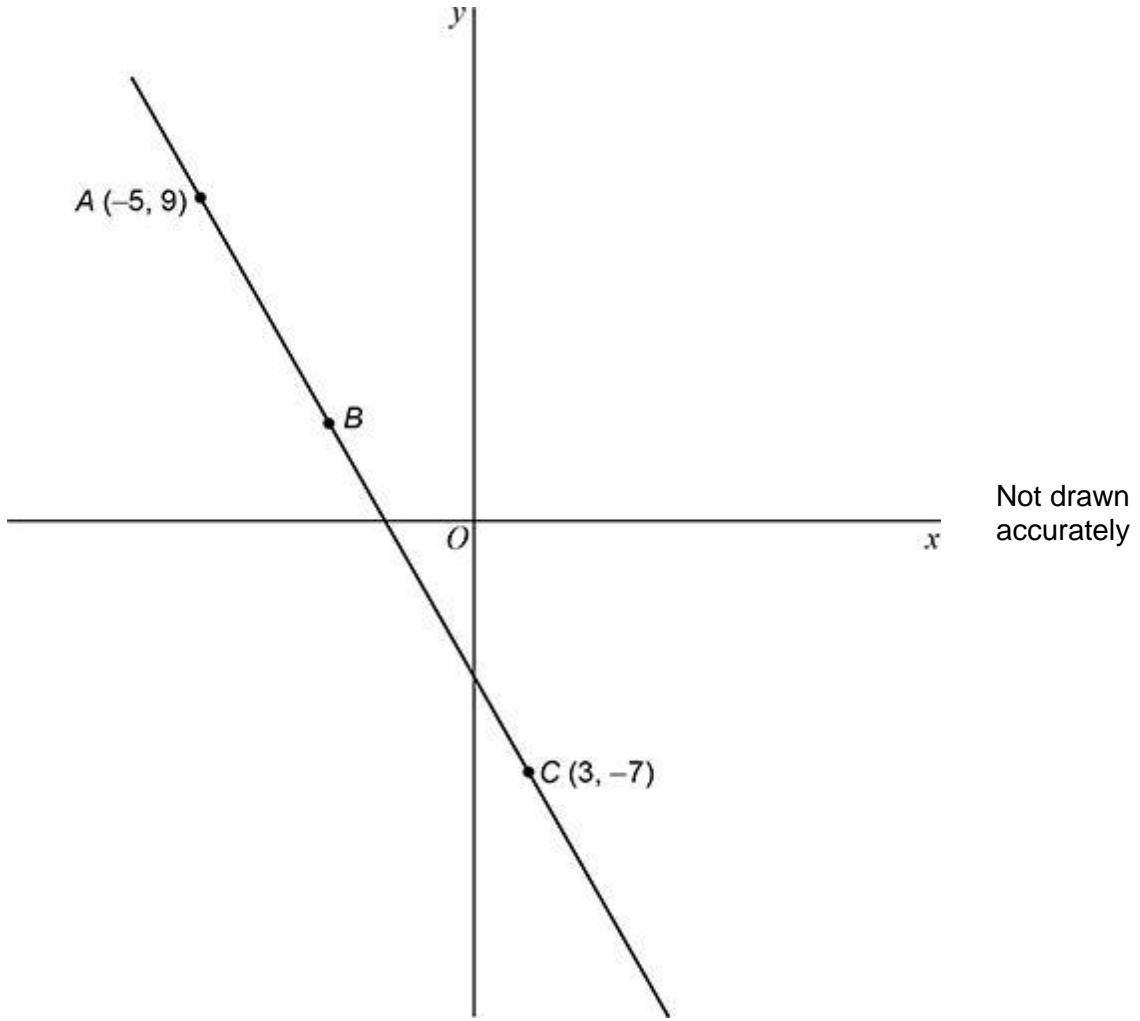

- (a) $AB : BC = 1 : 3$

Work out the coordinates of point B .

Answer (_____ , _____)

(3)

- (b) Work out the equation of the line perpendicular to AC that passes through C .

Q5.

ACB is a straight line.

A is the point $(0, 12)$, and B is the point $(6, 0)$

C is the midpoint of AB .

Line DCE is perpendicular to line ACB .

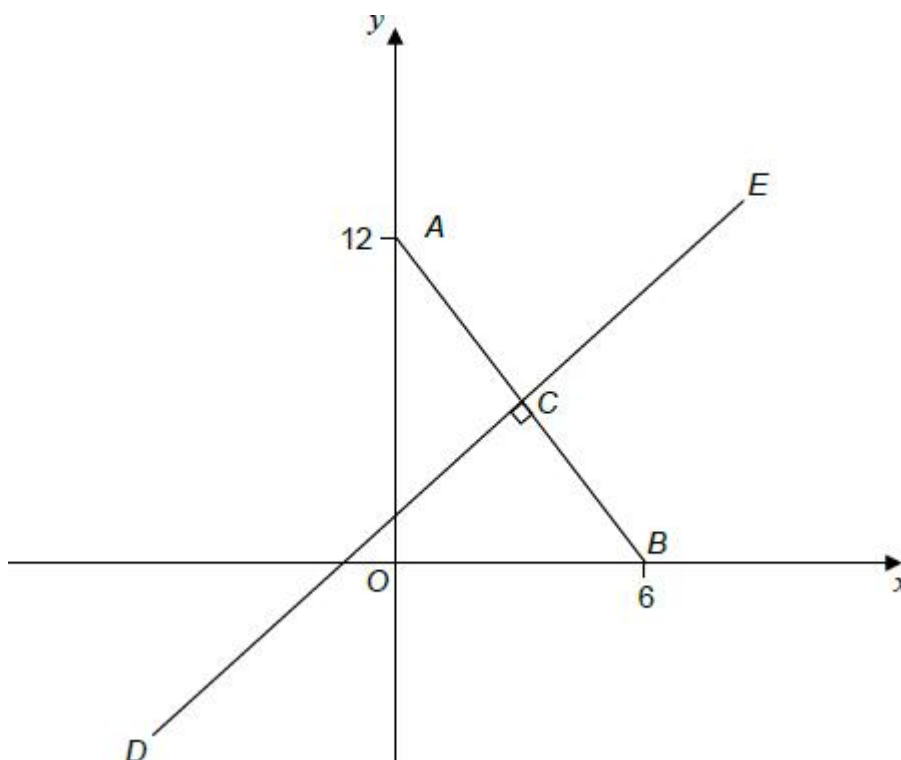

Not drawn accurately

Work out the equation of line DCE .

Answer _____

(Total 5 marks)

Transformations

Q1.

Quadrilateral $ABCD$ is shown.

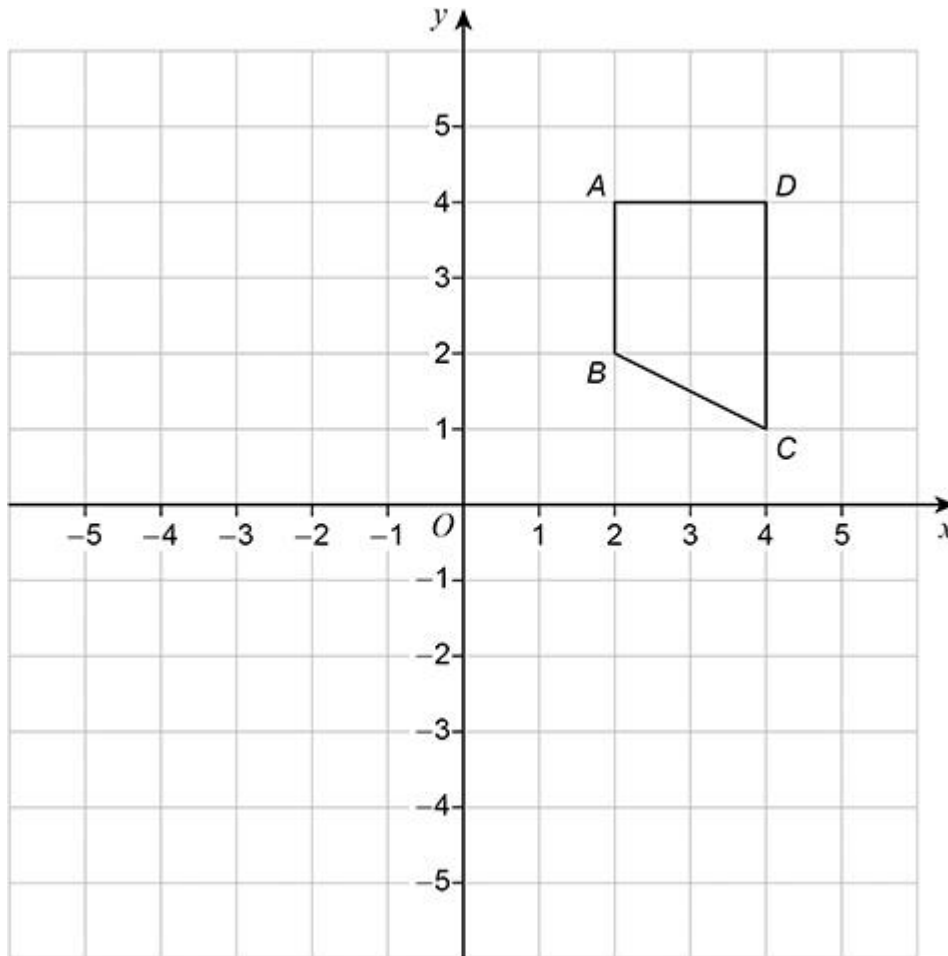

Work out the coordinates of C when $ABCD$ is rotated 90° clockwise about O then

translated by $\begin{pmatrix} -6 \\ 2 \end{pmatrix}$

Answer (_____ , _____)
(Total 2 marks)

Q2.

Shape A and shape B are shown on the grid.

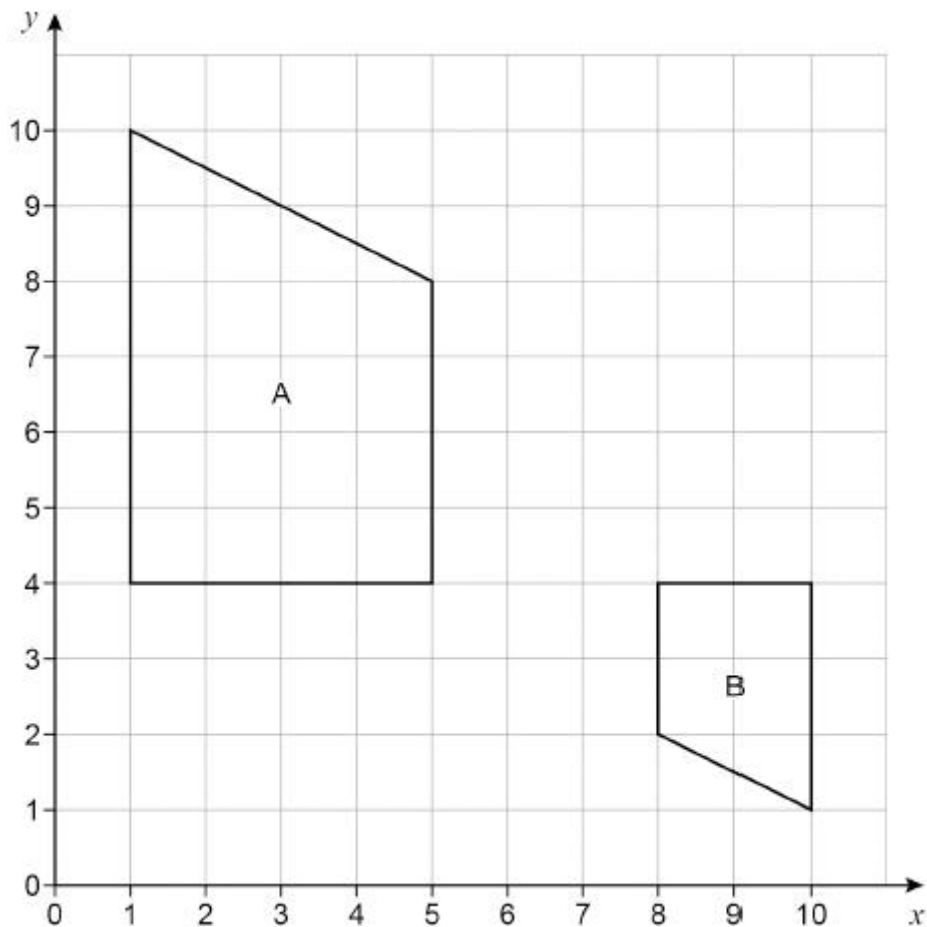

Describe the **single** transformation that maps shape A to shape B.

(Total 3 marks)

Q3.

(a) Here is triangle ABC .

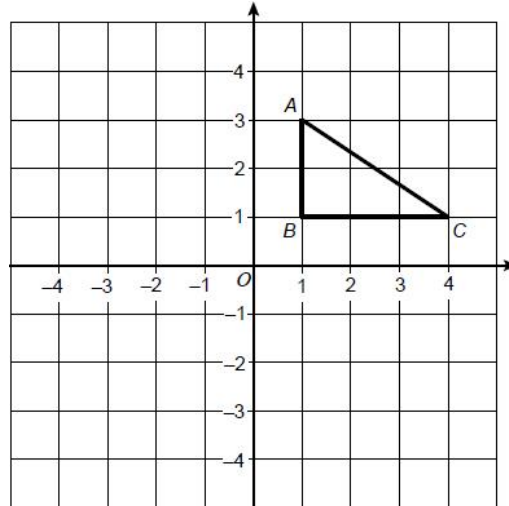

Describe fully a **single** transformation of the triangle for which
 all points on AB are invariant
 there are no other invariant points.

(1)

(b) Here is an L-shape $PQRSTU$.

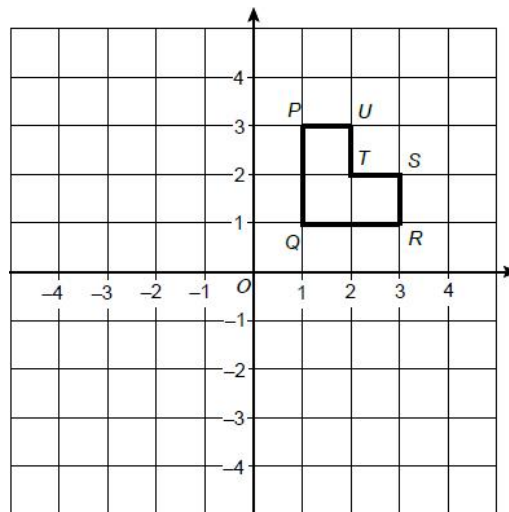

Describe fully a **single** transformation of the L-shape for which
 Q is invariant
 the line joining P and Q becomes horizontal
 the area of the L-shape does not change.

(2)
(Total 3 marks)

Volume of 3D shapes

Q1.

A box is the shape of half a cylinder on top of a cuboid.

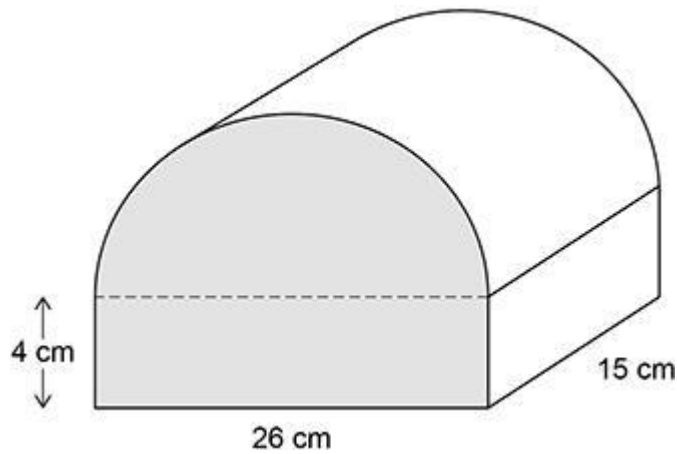

Work out the volume of the box.

Answer _____ cm^3
(Total 4 marks)

Q2.

Here are two solid cubes, X and Y.

The mass of X is 10.976 kg

The area of **each face** of X is 784 cm²

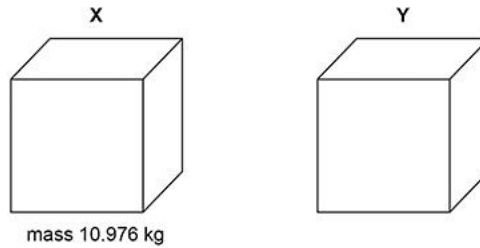

- (a) Zayan wants to know the density of Y.
He assumes that Y is identical to X.

What density should he get for Y?

Give your answer in **grams per cubic centimetre**.

Answer _____ g/cm³

(4)

- (b) In fact,

the mass of Y is less than the mass of X

the area of each face of Y is greater than the area of each face of X.

What does this mean about the actual density of Y?

Tick **one** box.

It is less than the answer to part (a)

It is equal to the answer to part (a)

It is greater than the answer to part (a)

It is not possible to tell

(1)

(Total 5 marks)

Q3.

Alec makes a bowl for dog food from a solid wooden cone. The sketches show how the bowl is made.

The cone has radius 9 cm and perpendicular height 30 cm
A smaller cone, with radius 6 cm, is removed.

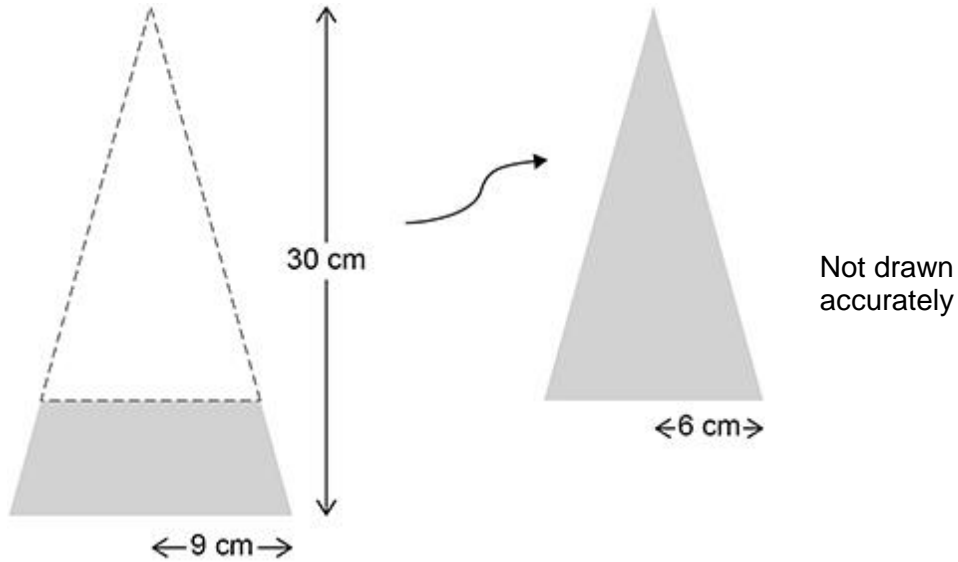

$\text{Volume of a cone} = \frac{1}{3} \pi r^2 h$ <p>where r is the radius and h is the perpendicular height</p>
--

A hemisphere with radius 6 cm is then removed.

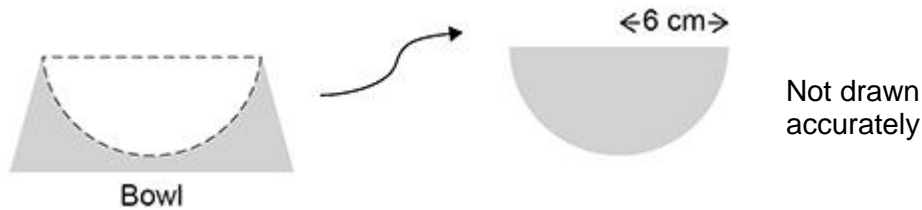

$\text{Volume of a hemisphere} = \frac{2}{3} \pi r^3 \quad \text{where } r \text{ is the radius}$

Work out the volume of the remaining wood that forms the bowl.

Answer _____ cm³
(Total 5 marks)

Q4.

Curved surface area of a cone = $\pi r l$ where r is the radius and l is the slant height.

The diagram shows a hollow cone made from thick glass.

The radius of the **outer** cone is 10 cm

The slant height of the **outer** cone is 25 cm

The radius of the **inner** cone is 5 cm

The slant height of the **inner** cone is 12.5 cm

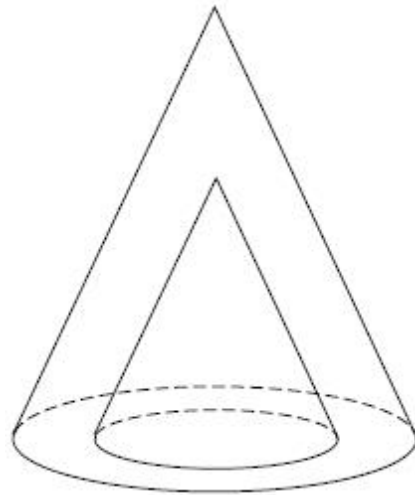

Work out the **total** surface area of the glass.

Answer _____ cm²
(Total 5 marks)